

Probable marks : 11**Scope of the syllabus :-**

- Introduction to microcontroller
- Study of 8051 architecture and programming model.
- Overview of other microcontrollers in 8051 family.
- Applications of microcontrollers

Q. 1 What is microcontroller ? Explain in short. **(Oct. 2004,2010, June 2016, March 2018)**

OR

Write a note on complete microprocessor system.

Ans. :

- 1) A microcontroller is a complete microprocessor system, consisting of microprocessor, limited amount of ROM or EPROM, RAM and I/O ports, built on a single integrated circuit.
- 2) Microcontroller is infact a microcomputer, but it is called so because it is used to perform control functions.
- 3) The designer of a microcontroller identify all the needs to build a simple microprocessor system and puts as many as possible in a single IC.
- 4) For example a microcontroller must include full or nearly full implementation of a standard microprocessor, ROM or EPROM, RAM, parallel I/O ports, timer, a clock, serial ports.
- 5) A microcontroller is more complex than a microprocessor because it consists of many I/O components.
- 6) e.g. Intel's 8048, 8051.

Q. 2 Define microcontroller. State any four advantages of the same over microprocessor based system. **(Mar. 02, 05, Oct. 05, 10, 19; July 19)**

Ans. :

-) A microcontroller is a complete microprocessor system, consisting of microprocessor, limited amount of ROM, RAM and parallel I/O ports, built on a single integrated circuit.
-) Advantages of microcontroller over microprocessor-based system :
- (i) The cost of microcontroller is less than a microprocessor-based system.
 - (ii) A microcontroller has more I/O components than a microprocessor-based system.
 - (iii) Microcontrollers can be used in wide variety of intelligent products such as in personal computers key-boards. Microprocessor-based systems cannot be used in such intelligent products.
 - (iv) Many low cost products such as electronic toys, electric drills, microwave ovens, VCRs are based on microcontrollers. This is not the case with microprocessor based system.

Q. 3 What are the main features of 8051 ?

OR Give any eight features of 8051.

(Mar 03, 04, 09, 11, 18, 19, 20, Oct. 03, 04, 05, 06, 07 08, 09)

Ans. : The main features of 8051 are as listed below :

- (i) The 8051 microcontroller has an 8-bit ALU.
- (ii) The 8051 has 4K byte ($4K \times 8$ bit) ROM or EPROM.
- (iii) The 8051 has 128 byte (128×8 bit) RAM.
- (iv) It has dual 16-bit timer event counter.
- (v) It has 32 I/O lines for four 8-bit I/O ports.
- (vi) It can address 64 kB of program memory.
- (vii) It can address 64 kB of data memory.
- (viii) It has powerful instruction set, consisting of 111 instructions.
- (ix) It has two external interrupts.
- (x) The 8051 has clock upto 12-MHz frequency.
- (xi) Full-featured serial port.

Q. 4 Draw an architectural block diagram of 8051 and explain it.

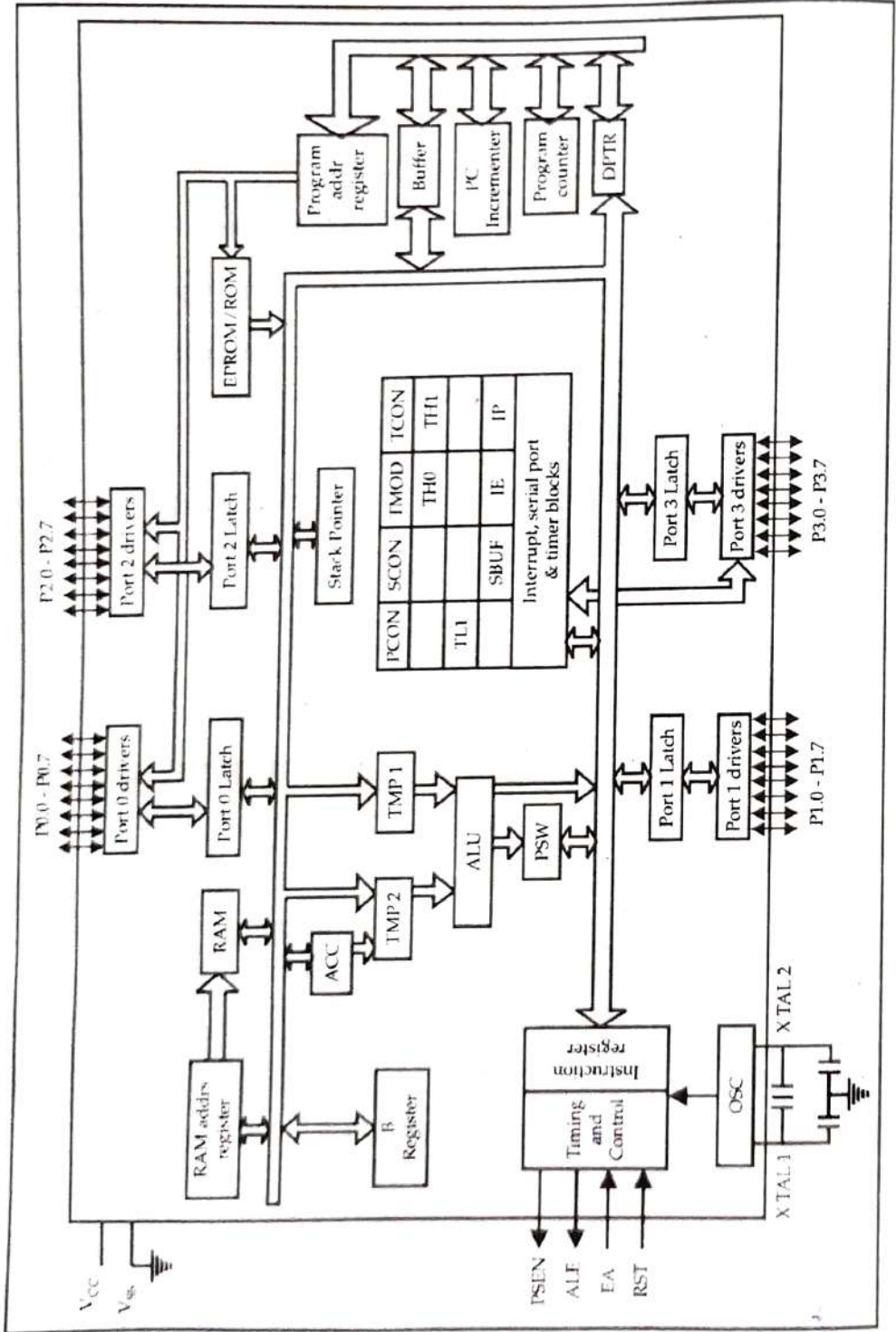

Ans. :

- 1) As shown in the internal block diagram of 8051, there are 32 pins for four 8-bit bidirectional ports.
- 2) In addition to these 32 pins, 8 pins are provided to connect clock crystal, timing and control signals and power supply.

- 3) The standard functions which make up microcontroller is in the centre of the diagram. This includes ALU, accumulator, stack pointer, a block of registers and general purpose register (B-register).
- 4) All these blocks are connected to 8051 internal 8-bit data bus through the series of registers.
- 5) These registers hold data during I/O transfer and control the I/O ports.
- 6) The architecture diagram also includes RAM and ROM. The 8051 has internal 4 kB ROM/EPROM and 128 bytes RAM.

Q.5 Explain 8051 memory mapping for 8051 microcontroller with the help of neat diagram.

(Oct.02,07, March 06,09,08,19,20; June 16, July 17,19)

OR Explain in detail how 8051 microcontrol addresses two separate memory spaces.

(Mar.05,11, Oct.03)

Ans.:

- 1) The 8051 addresses has two separate memory spaces :
 - i) Program memory space
 - ii) Data memory space.
- 2) The memory map for 8051 is shown in the following figure.

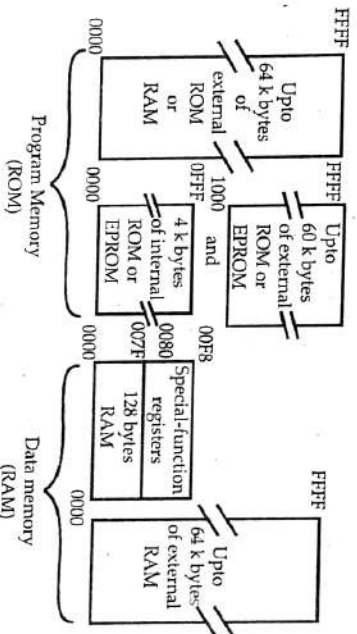

- 3) The program memory space is Read-only memory (ROM) space.
- 4) This memory space is used for storing programs and variable data. It is possible to read program instructions from this space, but the processor cannot write data into this memory.
- 6) All instruction fetches are taken from program memory space.
- 7) The data memory space is a read/write memory space.
- 8) The processor can read data from this memory space and can write data to this memory space.
- 9) It cannot execute instructions from this memory space. The 8051 internal RAM is in this memory space.
- 10) The 128 bytes of internal RAM provide general read/write data storage. Some part of this is often referred to as registers.

- 11) The 8051 has 22 special function registers which are not part of 128 bytes of RAM. They occupy memory space from 80H to F8H. These registers are used for their intended purpose.
- 12) The 4k byte program memory can be expanded by an additional 60k bytes, making it 64k bytes program memory. The data memory can also be expanded to 64k bytes.
- 13) The 8051 can also be operated with common memory. In this case, 8051 only has 64k bytes of total external memory. In this configuration, 8051 can input block of data through its serial communications port load that data in memory and then execute that data as a program. This is called downloaded program. It is a very common technique used to change the program operating in a remote microprocessor - based controller.

Q. 6 Give the main features of 8048 microcontroller.

Ans. : The main features of 8048 are as listed below :

- (i) 8048 has clock having frequency 2 MHz to 4 MHz.
- (ii) It has 27 I/O lines.
- (iii) It has 1 K byte ROM or EPROM.
- (iv) It has 64 bytes RAM.
- (v) It has one 8-bit timer event counter.
- (vi) Address capacity of 8048 is 4 KB.

Q. 7 Explain in detail other microcontrollers in 8051 family. OR

List all microcontrollers of 8051 family and state one feature of each.

(Mar.2010,2011, Oct. 02, Oct.04; March 18)

Ans. : 8051 is a second generation microcontroller.

I) 8048, 8049, 8050 :

- 1) Intel's first microcontroller was 8048. The 8048, 8049 and 8050 all have identical architectures with the exception of memory size.
- 2) In each case, the memory doubles. 8048 supports 1K byte of internal memory. 8049 supports 2k bytes of internal memory and 8050 supports 4K bytes of internal memory.
- 3) 8048 has 64 bytes internal RAM, including 32 bytes of register/memory location. The 8049 and 8050 have a total of 128 and 256 bytes of RAM respectively.
- 4) These microcontrollers are low cost products and hence are very popular.

II) 8052 :

- 1) 8052 is a simple expansion of 8051.
- 2) 8052 has 8K bytes of onboard ROM and 256 bytes of onboard RAM.
- 3) 8052 allows programmers to write larger programs and that can use more data.
- 4) The cost of 8052 is more than that of 8051.
- 5) The 8052 also has one extra 16-bit counter-timer. This counter-timer gives more flexibility.

III) 8031 and 8032 :

- 1) The alternative versions of 8051 and 8052 are 8031 and 8032.
- 2) These devices do not have any on board ROM. It may use external ROM for program memory.
- 3) These are excellent devices for prototyping and low-volume products.

IV) 8052 AH-BASIC :

- 1) Another form of 8052 is 8052 AH-BASIC. This special 8052 has BASIC programming language in ROM.
- 2) Using BASIC instructions, a programmer can write instructions for this 8052 rather than assembly language.

Q. 8 Compare between microcontrollers 8051 and 8052.**(Oct. 2006/2009, March 2011)****Ans.:**

- 1) Microcontroller 8051 has 4k bytes of ROM, whereas 8052 has 8k bytes of onboard ROM or EPROM.
- 2) Microcontroller 8051 has 128 bytes of RAM, whereas 8052 has 256 bytes of onboard RAM.
- 3) Microcontroller 8051 has a dual 16-bit timer event counter whereas 8052 has an extra 16-bit timer event counter.
- 4) The cost of microcontroller 8051 is less than that of microcontroller 8052.
- 5) Both 8051 and 8052 are used in high volume applications and both allow us to write large program. But in 8052 we can write larger programs than that in 8051.

Q. 9 What is a Microcontroller ? State three expanded features of 8052 over 8051 microcontroller.**(Mar. 04, 06; July 19)****Ans.:**

- (1) Microcontroller : A microcontroller is a complete microprocessor system, consisting of microprocessor, limited amount of ROM, RAM and parallel I/O ports, built on a single integrated circuit.
- (2) Microcontroller is infact a microcomputer, but it is called so because it is used to perform control functions.
- (3) Expanded features of 8052 over 8051 microcontroller are as follows :
 - (a) **ROM :** Microcontroller 8052 has 8 Kbytes of onboard ROM or EPROM whereas 8051 has 4 Kbytes of ROM.
 - (b) **RAM :** Microcontroller 8052 has 256 bytes of onboard RAM whereas 8051 has 128 bytes of RAM.
 - (c) **Time-event counter :** 8052 has an extra 16-bit time event counter whereas 8051 has a dual 16-bit timer event counter.

Q. 10 Give the applications of microcontroller. OR**Explain the various applications of microcontroller.****(Mar. 02, 10 Oct. 08, 09; June 16; July 2017)****Ans.:**

- 1) Microcontroller is a single chip microcomputer.
- 2) They are used as independent controllers in machines or as slaves in distributed processing.
- 3) They are used as machine tools, chemical processors, medical instrumentation and sophisticated guidance control.

- 4) Some applications require simple timing and bit set/reset functions; other require high speed data processing capability.
- 5) Many low cost products such as electronic toys, microwave ovens, VCRs are based on microcontrollers.
- 6) A home security system, a tape deck and intelligent multimeter can also be build by using microcontroller.
- 7) The personal computer keyboards are implemented with a microcontroller. It replaces scanning, debounce, matrix decoding and serial transmission circuits.

Q. 11 Differentiate between Micro-controller and a Micro-processor.

March 2016

Ans. :

Micro-controller	Micro-processor
1. Micro-controller is a chip which is called single chip computer	1. A Microprocessor is a general purpose device which is called a CPU
2. Microcontroller included RAM, I/O Port, ROM, Timer in a single chip	2. Microprocessor do not contain on chip I/O ports, Timer, Memories etc.
3. Microcontroller based system design is simple and cost effective	3. Microprocessor based system designer is complex and expensive
4. Microcontroller have no advantage of designing RAM, ROM and I/O port	4. Microprocessor have advantage of versatility such that designer can decide the amount of RAM, ROM and I/O port as needed.

Q. 12 Select the correct alternative and rewrite the following.

1. _____ is a microcontroller chip.
 (i) 8085 (ii) 80286 (iii) 8051 (iv) Pentium
2. 8051 has _____ RAM.
 (i) 128 bytes (ii) 64K bytes (iii) 1K bytes (iv) None of these
3. The 8051 microcontroller has instruction set of _____ instructions.
 (i) 99 (ii) 111 (iii) 120 (iv) 110

Mar. 02 08

Oct. 08

4. 8051 has clock upto _____ frequency.
 (i) 12 MHz (ii) 4 MHz (iii) 9 MHz (iv) 6 MHz

Oct. 08

5. The 8051 is a _____ generation microcontroller.
 (i) First (ii) Second (iii) Third (iv) Fourth

Ans. : (ii) Second

6. The 8051 microcontroller has an ALU of _____ bit capacity.

Oct. 08

- (i) 8 (ii) 16 (iii) 32 (iv) 64
- Ans. :** (i) 8